

FlowSonic

POWERED BY *sentronics*®

The FlowSonic® LF ultrasonic sensor from Sentronics™ represents a breakthrough in fuel flow measurement technology for automotive engines of every type. The FlowSonic LF has been designed for the ultra low-volume fuel flow conditions found in today's high-efficiency road car engines, making it an ideal tool for R&D as well as emissions testing to the new RDE and WLTP standards. Key features and advantages include:

- ✓ Compact, lightweight, no moving parts
- ✓ Easily installed on test bench or vehicle
- ✓ Highly accurate and repeatable
- ✓ Extremely robust and vibration-tolerant
- ✓ -40°C to +120°C temperature range
- ✓ Internal processing and diagnostics
- ✓ Fast measurement rate for dynamic flows
- ✓ CAN, TTL pulse, analog output formats
- ✓ Class-leading ultrasonic turndown ratio
- ✓ Minimal operating and maintenance cost

FlowSonic® LF Low-Flow Sensor



FlowSonic® LF Dimensions (mm)

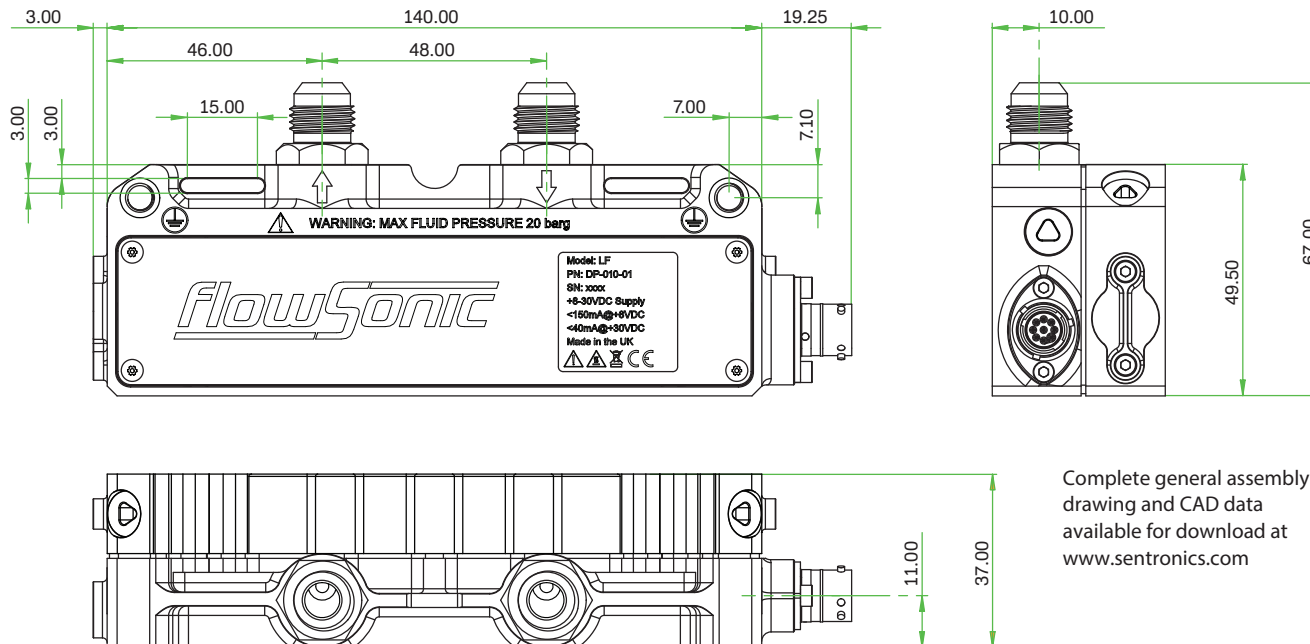

Complete general assembly drawing and CAD data available for download at www.sentronics.com

FlowSonic® LF Pin Out Functions

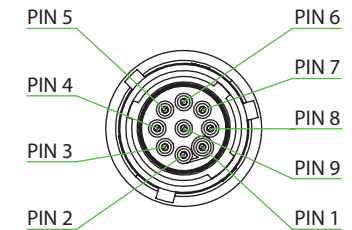

Deutsch ASD006-09PC-HE Sensor Connector

Pin 1	Supply +
Pin 2	CAN High
Pin 3	CAN Low
Pin 4	TTL Pulse Output
Pin 5	Analog Output
Pin 6	Comms A
Pin 7	Comms B
Pin 8	CAN Select
Pin 9	Ground (GND)

Model References

Model	Colour	Part Number	Description
LF	●	DP-010-02	FlowSonic® LF Low Flow Sensor

Measurement Performance

Flow Measurement

Repeatability	± 0.15% of reading
Uncertainty*	± 0.5% of reading
Turndown ratio	500:1
Operating flow range	± 0-4000 ml/min
Measurement flow range	8-4000 ml/min
Measurement rate	2.2 kHz
Maximum operating pressure	20 barg (2000 kPag)
Pressure drop at maximum flow	< 20 kPa (4000 ml/min for pump petrol @ 20°C)
Fluid temperature range	-20°C to +120°C
Ambient temperature range	-40°C to +120°C
Temperature Measurement	2 x 1000 Ohm RTD (1/3 DIN standard)

* Calculated according to ISO/TR using root-sum square method yielding 95% confidence

Mechanical

Dry weight	330 g
Fluid capacity	15 ml
Wetted materials	FPM, anodised aluminium alloy, stainless steel
Fuel line connection	-6AN fittings 9/16-inch UNF thread
Deutsch sensor connector	ASDD006-09PC-HE
Deutsch mating connector	ASDD606-09SC-HE

Environmental

Storage temperature	-40°C to 85°C
External pressure rating	300 kPa
Environmental protection	IP69K (when mated to connector)

Electrical Supply

Voltage	8V to 30V DC
Current	< 95 mA @ +12V DC
Voltage protection	Over-voltage 45V DC, reverse polarity -45V DC

CAN Communications

Design standard	ISO 11898-2 (high-speed applications)
Message format	2.0A (11-bit identifier)
Baud rate	1 Mbit/sec
CAN termination resistor	No

TTL Pulse Output

Voltage output range	0-5V
Pulses per cc	3000 (fully configurable)
Duty cycle	50%
Output resistance	1.0 kOhm

Analog Output

Voltage output range	0-10V DC
Resolution	16-bit
Output resistance	47.0 Ohm
Load resistance	> 1.0 kOhm

Configuration Interface

Configuration Interface	3.3V serial interface
-------------------------	-----------------------

Fuel Compatibility

Fuel Compatibility	Petrol, diesel, bio-diesel, ethanol, methanol please contact us about other fluids
--------------------	---

Specifications subject to change without prior notice