

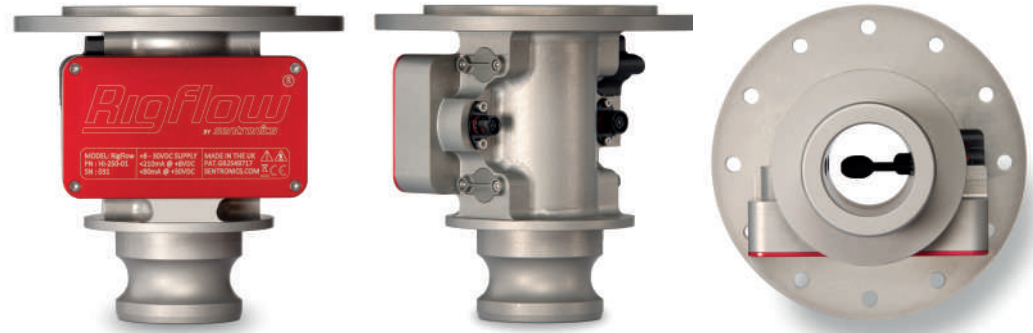

Motorsport Pit Tank Sensor

The RigFlow is specifically designed for accurately measuring dispensed fuel during a pit stop. The technology allows both teams and governing bodies to independently assess exactly how much fuel has been dispensed from the 200L FIA® pit tank.

- ✔ No moving parts
- ✔ Highly accurate and repeatable
- ✔ -10°C to +50°C temperature range
- ✔ Internal processing and diagnostics
- ✔ Fast measurement rate for dynamic flows
- ✔ Compatible with wide range of fuel types
- ✔ Standard fitment for 200L FIA® Refuelling Pit Tank
(Constructed as per Appendix J Drw N°252-7)



Dimensions (mm)

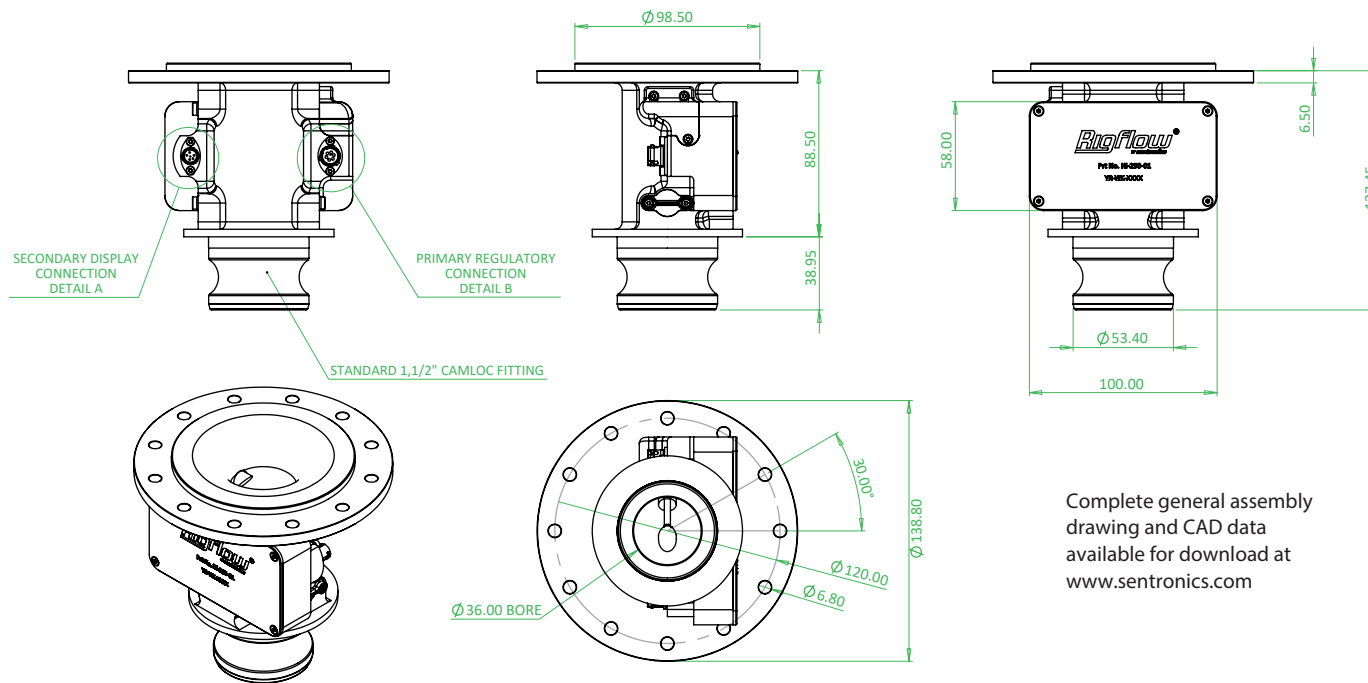

Complete general assembly drawing and CAD data available for download at www.sentronics.com

Pin Out Functions

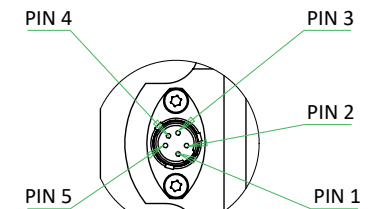

DETAIL A
SCALE 1:1
SOURIAU 8STA0-0205SN

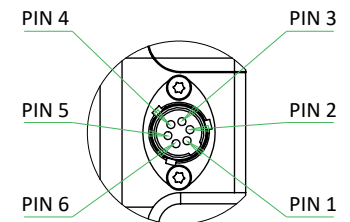

DETAIL B
SCALE 1:1
SOURIAU 8STA0-0406SN

Model References

Model	Colour	Part #	Description
RigFlow	●	HI-250-01	IMSA / FIA Refuelling Pit Tank Flow Sensor

Measurement Performance

Flow Measurement

Measurement rate	200 Hz
Repeatability	± 0.3% of reading
Uncertainty*	± 0.75% of reading
Operating flow range	0 - 250 l/min
Calibrated measurement range	50 - 250 l/min

Fluid Temperature Measurement

Accuracy	± 0.5°C
----------	---------

* Calculated according to ISO/TR using root-sum square method yielding 95% confidence

Flow Outputs and Functions

Calibrated volumetric flow rate (ml/min)
Calibrated cumulative volumetric flow (ml)
Calibrated mass flow rate (g/min)
Calibrated cumulative mass flow (g)
Max/min logging
Elapsed time counter (power on, ETI)
Run-time (flow time, RTI)
Speed of sound (m/s)
Diagnostics via CAN

Fuel Compatibility

Pump petrol or diesel
WEC standard E20
F1 petrol blends
Neat butanol, neat methanol or neat ethanol
Methanol/petrol or ethanol/petrol

Mechanical

Dry weight	895 g
O-ring seal elastomer	FPM fluorocarbon
Wetted materials	FPM, anodised aluminium alloy, stainless steel
Fluid operating pressure	10barG

Environmental

Storage temperature	-40°C to +85°C
Operational temperature	-10°C to +50°C

Electrical

Voltage	8V to 30V DC
Current	< 200mA
Voltage protection	Over-voltage 45V DC, reverse polarity -45V DC
Primary sensor connector	SOURIAU 8STA0-0406SN
Primary mating harness connector	SOURIAU 8STA6-0406PN
Display connector	SOURIAU 8STA0-0205SN
Display mating harness connector	SOURIAU 8STA6-0205PN

CAN Communications

Design standard	ISO 11898-2 (high-speed applications)
Message format	2.0A (11-bit identifier)
Baud rate	500 kbit/sec
CAN termination resistor	No
Message/Channel description	Please contact us for the .dbc

Primary Connector Pin-out (Souriau 8STA0-0406SN)

Pin 1	V+ Supply (12V)
Pin 2	GnD
Pin 3	CAN Hi
Pin 4	CAN Lo
Pin 5	Comms Tx from sensor to PC (factory only)
Pin 6	Comms Rx from PC to sensor (factory only)

Display Connector Pin-out (Souriau 8STA0-0205SN)

Pin 1	N/C
Pin 2	GnD
Pin 3	CAN Hi
Pin 4	CAN Lo
Pin 5	N/C